



## JOHN THOMPSON ENVIROPAC™

Oil/Gas-fired Boiler



# ACTOM

# JOHN THOMPSON ENVIROPAC™ Oil/Gas-fired Boiler

## Features & Benefits

- Design and manufacture to latest European Standard, EN12953 for a design pressure of 1100 kPa (Designs also available up to 2 500 kPa)
- Three-pass conventional firetube wet-back design with spiral-tubes in both tube passes
- Flanged end-plates in place of flat end-plates on selected boilers to eliminate tee-butt weld joints. This will reduce susceptibility to corrosion fatigue and extend boiler life

- Latest spiral-tube technology with heat transfer up to 100% greater than normal plain tubes to reduce gas outlet temperature to only 15°C above steam saturation temperature
- High thermal efficiency of up to 91.5% at rated output to reduce fuel consumption and CO<sub>2</sub> emission. (An economiser can be provided for an ultra-high efficiency)
- Combustion equipment to suit a wide range of oil viscosities and gas compositions

- Total package incorporates burner, fan, feed-water pump and controls, control panel and all necessary valves and fittings
- Twin burner boilers are available for boiler ratings above 25 000 kg/h
- All boilers are inspected and certified by an Approved Inspection Authority before dispatch
- Quality Management Systems are audited by SABS and satisfy the requirements of SANS ISO 9001:2008.

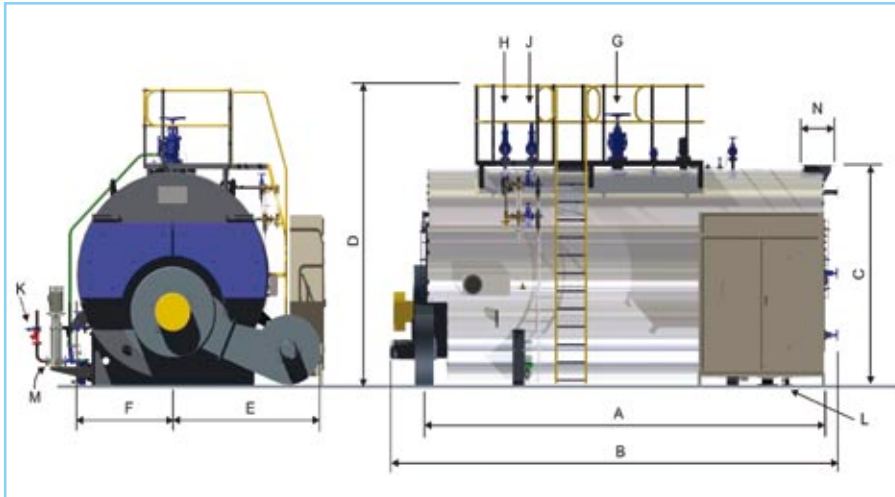

## Notes

1. Oil consumption based on NCV 40,6 MJ/kg, GCV 43,4 MJ/kg (150 cSt @ 50°C)
2. Gas (1) consumption based on Sasol Natural Gas, GCV 41,3 MJ/m<sup>3</sup> (101,3 kPa, 0°C)
3. Gas (2) consumption based on Methane-Rich Gas, GCV 35,7 MJ/m<sup>3</sup> (101,3 kPa, 0°C)
4. All dimensions, masses and fuel consumption are approximate based upon a boiler working pressure of 1000 kPa
5. Full range of support services are available from our regional offices
6. Whilst all information is given in good faith, it should be confirmed before establishing any contractual commitment.

Boiler Model Number		TE	500	650	800	1 000	1 200	1 600	2 000
Evaporation:	From & at 100°C	kg/h	5 000	6 500	8 000	10 000	12 000	16 000	20 000
	At 1000 kPa, feedwater 20°C	kg/h	4 190	5 440	6 700	8 375	10 050	13 400	16 750
Boiler Rating		kW	3 134	4 075	5 015	6 269	7 522	10 030	12 537
Dimensions in mm:  (includes 200mm plinth)	A	mm	4 750	4 750	4 750	4 750	5 400	6 250	6 250
	B	mm	6 150	6 150	6 250	6 250	7 000	7 850	7 850
	C	mm	2 675	2 975	3 075	3 325	3 405	3 795	4 075
	D	mm	3 875	4 175	4 275	4 525	4 605	4 995	5 275
	E	mm	1 500	1 550	1 600	1 700	1 750	2 400	2 700
	F	mm	1 200	1 250	1 300	1 400	1 450	1 600	1 850
Main Steam Valve	G	mm	100	150	150	150	150	200	200
Safety Valve Exhaust Diameter	H	mm	50	65	65	80	80	100	100
Safety Valve Exhaust Diameter	J	mm	50	65	65	80	80	100	100
Feed Check Valve Diameter	K	mm	32	32	50	50	50	50	50
Blowdown Valve Diameter	L	mm	50	50	50	50	50	50	50
Feedpump Inlet Diameter	M	mm	32	40	40	40	50	50	65
Recommended Stack Diameter	N	mm	500	550	600	700	750	850	950
Nominal Fuel Consumption	Oil	kg/h	302	392	482	602	723	961	1 202
	Gas (1)	m <sup>3</sup> /h	329	427	525	656	788	1 047	1 309
	Gas (2)	m <sup>3</sup> /h	381	496	609	761	915	1 216	1 520
Mass:	Empty	tons	8,9	12,2	13,2	15,6	17,7	28,2	32,3
	Operating	tons	18,3	24,1	25,9	30,8	35,5	55,0	63,3
	Full of Water	tons	19,9	26,0	28,3	33,3	39,3	60,0	69,7