



JOHN THOMPSON REDIPAC™
Oil/Gas-fired Boiler



ACTOM

JOHN THOMPSON REDIPAC™ Oil/Gas-fired Boiler

Features & Benefits

- Three-pass, reverse-flame, wet-back design with a low furnace rating
- High thermal efficiency of up to 90% when oil-fired and 89% when gas-fired
- Combustion equipment to suit a wide range of oil viscosities and gas compositions
- Design and manufacture to latest European Standard, EN12953 for a design pressure of 1100 kPa. (Designs also available up to 3 000 kPa)
- Total package incorporates burner, fan, feed-water pump and controls, control panel and all necessary valves and fittings
- All boilers are inspected and certified by an Approved Inspection Authority before dispatch
- Quality Management Systems are audited by SABS and satisfy the requirements of SANS ISO 9001:2008.

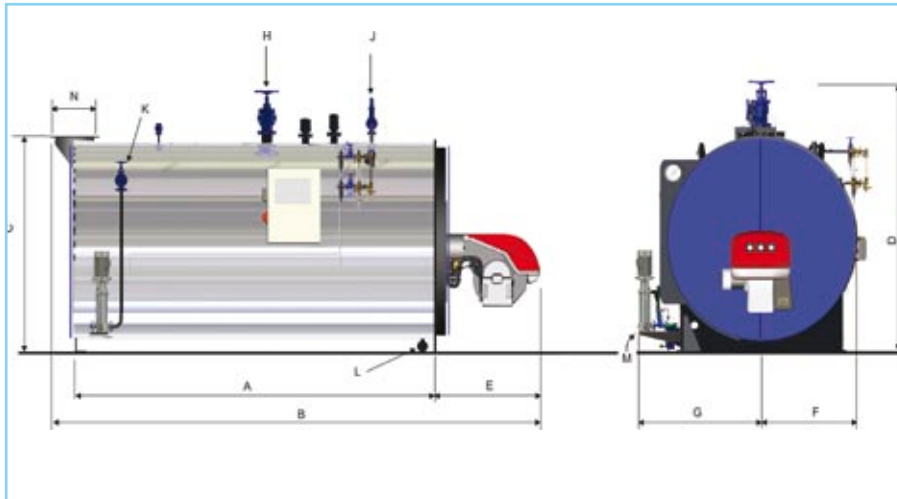

Notes

1. Oil consumption based on NCV 40,6 MJ/kg, GCV 43,4 MJ/kg (150 cSt @ 50°C)
2. Gas (1) consumption based on Sasol Natural Gas, GCV 41,3 MJ/m³ (101,3 kPa, 0°C)
3. Gas (2) consumption based on Methane-Rich Gas, GCV 35,7 MJm³ (101,3 kPa, 0°C)
4. All dimensions, masses and fuel consumption are approximate based upon a boiler working pressure of 1000 kPa
5. Full range of support services are available from our regional offices
6. Whilst all information is given in good faith, it should be confirmed before establishing any contractual commitment.

Boiler Model Number		TR	100	200	300	400	500
Evaporation:	From & at 100°C	kg/h	1 000	2 000	3 000	4 000	5 000
	At 1 000 kPa, feedwater 20°C	kg/h	837	1 674	2 511	3 348	4 185
Boiler Rating		kW	627	1 254	1 880	2 507	3 134
Dimensions in mm	A	mm	2 400	3 000	3 600	3 600	4 200
	B	mm	3 288	4 125	4 860	5 003	5 658
	C	mm	1 670	1 970	2 170	2 320	2 370
	D	mm	1 985	2 365	2 650	2 800	2 905
	E	mm	710	890	1 000	1 090	1 090
	F	mm	675	825	925	1 000	1 025
	G	mm	920	1 070	1 180	1 245	1 270
Main Steam Valve	H	mm	50	65	80	100	100
Safety Valve Exhaust Diameter	J	mm	32	50	65	65	80
Feed Check Valve Diameter	K	mm	25	25	32	32	32
Blowdown Valve Diameter	L	mm	32	32	32	32	32
Feed Pump Inlet Diameter	M	mm	25	25	32	32	32
Recommended Stack Diameter	N	mm	250	350	400	500	550
Nominal Fuel Consumption	Oil	kg/h	63	125	189	251	309
	Gas (1)	m ³ /h	69	136	206	273	337
	Gas (2)	m ³ /h	80	158	239	318	391
Mass:	Empty	tons	2.21	3.76	5.42	6.18	7.69
	Operating	tons	3.52	6.19	9.05	10.38	12.68
	Full of Water	tons	3.74	6.73	9.76	11.18	13.72